

## Parallel / SSI - Converter PU-20



- **Module to convert parallel data 28 bit into synchronous-serial data**
- **Switching threshold adjustable: 1,4 VDC / 12 VDC**
- **Code conversion of gray in binary form possible**
- **SSI protocol + checksum for TR evaluation unit**

### Electrical Data

|  |  |
|--|--|
| Operating Voltage.....                 | 11-29 V DC   |
| Power Dissipation (No Load) .....      | < 2 Watt   |
| Encoder-Module                         |  |
| Number of Parallel-Inputs.....         | 28   |
| Input Impedance .....                  | 4,7 kΩ   |
| Switching Threshold.....               | adjustable by DIP-switches                                     |
| TTL-Level .....                        | 1,4 VDC  |
| US-Level.....                          | 12 VDC   |
| Edition interface.....                 | SSI (synchronous-serial)                                       |
| Clock Input.....                       | Optocoupler  |
| Data Output.....                       | RS422 (2-wire)   |
| Clock Frequency .....                  | 80 kHz ... 1 MHz   |
| No Pulse Period.....                   | min. 24μs  |
| Min. Clock Number.....                 | = Number of Parallel-Data                                      |
| Output Format.....                     | on beginning with MBS  |
| Code (adjustable).....                 | standard (Gray) or from Gray in binary                         |
| Number of Data Bits (adjustable) ..... | 28 data bits without checksum, 28 data bits + 15 bits checksum |

### Environmental Data

|   |   |
|---|---|
| Electromagnetic compatibility (EMC) ..... | EN 61000-4-2 (IEC-801-2) / EN 61000-4-4 (IEC-801-4) |
| Operating temperature.....                | 0 bis +60°C   |
| Storage temperature range.....            | -20 bis +50°C                                       |
| Protection .....                          | IP 30 (DIN 40 050)                                  |

**Block diagram PU-20**

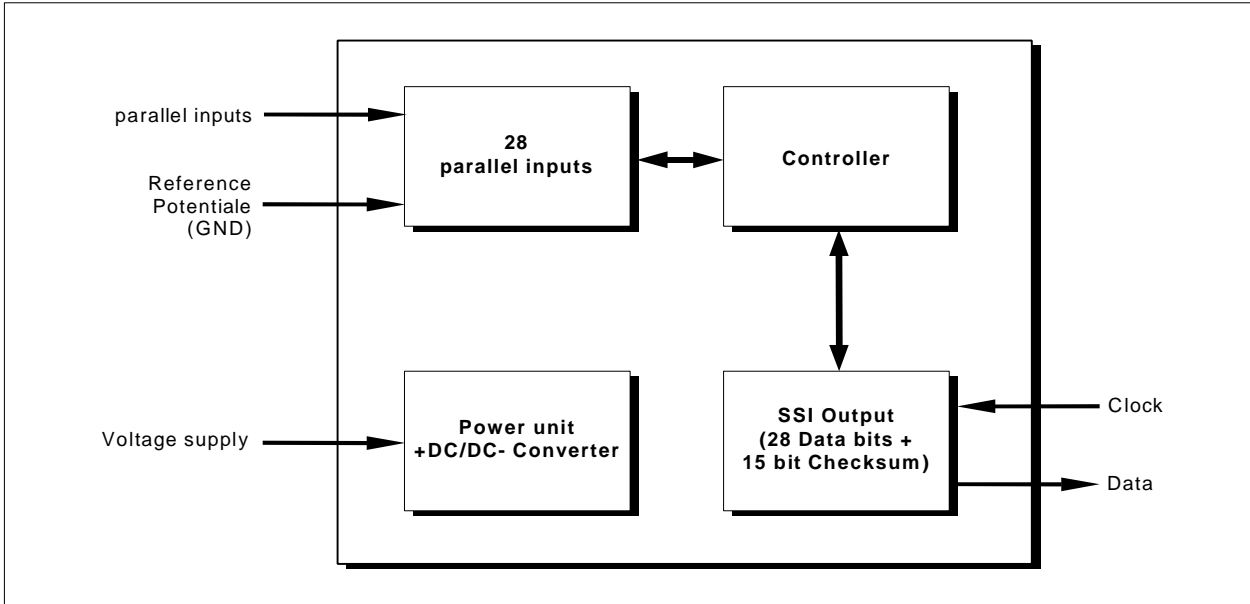

**Dimensional Drawing**

