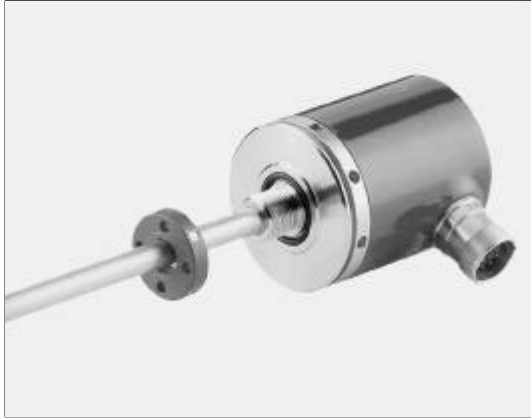
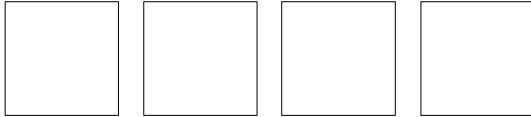

Linear-Encoder LA-66-K A

- **High Pressure Type, Makes it Possible for Installation into Hydraulic Cylinders**
- **For Linear Measurement**
- **Non Contact and Wear Free**
- **Justify over set inputs**
- **Analog Interface**

7**Electrical Data**

Measurement Principle	Magnetostrictive
Measuring Length (Stroke) Standard (mm)	150, 300, 500, 700, 750, 1000, 1500, 2000, 2500, 3000
	> 3000 by request
Resolution	max. 0.05 mm
Operating Voltage	24 V DC \pm 10 %
Power Dissipation (no load)	< 4 Watt
Analog Voltage Interface	0 - 10 V, 10 - 0 V, \pm 5 V, \pm 10 V
Impedance	min. 680 Ω
Analog Current Interface	0 - 20 mA, 4 - 20 mA
Impedance	max. 500 Ω
Cycle Time	See Dimensional Drawing
Data Transmission Length	
Dependent on Shield Design	max. 10 m for Analog Voltage Interface
	max. 1000 m for Analog Current Interface
Inputs	
Zero Set	For setting the start point of the analog signal
Span Set	For setting the end point of the analog signal
Logic Levels	"0" < + 2 V DC, "1" > + 8 V DC, max. 30 VDC
Pin Configuration	Upon request

Environmental Data

Electromagnetic compatibility (EMC)	EN 61000-4-2 (IEC-801-2) / EN 61000-4-4 (IEC-801-4)
Operating Temperature	0°-70°C (32° to 158° F) (Optional -20° to +70°C) (-4° to 158° F)
Storage Temperature	-30° to +80°C (-22° to 178° F)
Relative Humidity	98 % (non condensing)
*Protection Class	IP 43 (DIN 40 050)
* The protection class of the sensor can be effected by the type of connector used.	

Mechanical Data

Linearity	< 0.05 % of Measuring Length
Repeatability	≤ 0.01 mm
Hysteresis	< 0.1 mm
Temperature Coefficient	< 5 μm / °C
Vibration (Sinus 50-2000 Hz)	
per DIN IEC 68-2-6	≤ 100 m/s ² (10g)
Shock (11ms) per DIN IEC 68-2-27	≤ 1000 m/s ² (100g)
Pressure Resistance (Option)	600 bar
Rod Material	Cr/Ni-Mixture
Magnetic Field	< 3 mT (mili Tesla)
Operating Speed and Mounting Orientation	No restrictions
Magnet Type (Standard)	T4-M33
Rod Mounting	Option
Mechanical Special Types	Upon Request
Connector	8 pin MIL-Connector

Dimensional Drawing

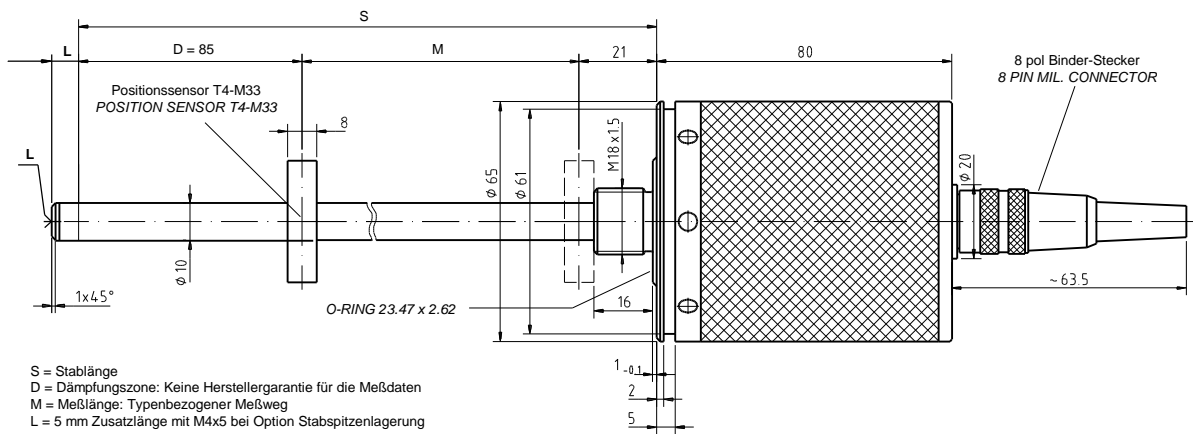

S = Stablänge
 D = Dämpfungszone: Keine Herstellergarantie für die Meßdaten
 M = Meßlänge: Typenbezogener Meßweg
 L = 5 mm Zusatzlänge mit M4x5 bei Option Stabsitzenlagerung

S = TOTAL LENGTH
 D = DAMPENING ZONE: IN THIS AREA NO MEASURING SIGNAL IS PRODUCED
 M = EFFECTIVE LENGTH
 L = 5 MM ADDITIONAL LENGTH WITH M4x5 FOR OPTION ROD MOUNTING

Positionssensor T4-M33
 POSITION SENSOR T4-M33

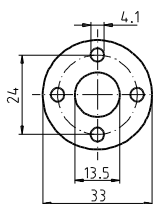

Meßlänge M (mm) EFFECTIVE LENGTH M (mm)	Stablänge S (mm) TOTAL LENGTH S (MM)	Zykluszeit (ms) CYCLE (ms)	Auflösung (mm) RESOLUTION (MM)
150	256	0,5	0,1
300	406	0,5	0,1
500	606	0,5	0,12
700	806	1	0,17
750	856	1	0,18
1000	1106	1	0,25
1500	1606	2	0,37
2000	2106	2	0,5
2500	2606	2	0,6
3000	3106	2	0,75